

# 10" BLCD Benchtop Table Saw

## FEATURES

### Saw Blade vs Sanding Disc

10 inch Table Saw can quickly transform into a Disc Sander by simply replacing the saw blade with a sanding disc. applicable from 45 ° to 90 ° .



### Rectangular Dado Insert

**Spindle Lock**  
for quick blade replacement.

**Quick Release Blade Guard**  
for changing Blade.

### Quick Elevation

Faster elevation than most of the saws on the market.

**Rear Extension Wing**  
to support wooden pieces.

### Overload Protection

Normal cutting shows solid green while red signal flashes as overload is triggered.

### Variable Speed Adjustment Knob

Multi-speeds with easy adjustment knob.

### L Rip Fence

L shaped Fence attached to Rip Fence allowing additional

### Tool Storage

Handy to store Miter Gauge, Riving Knife, Blade Wrench.

### Magnetic Switch

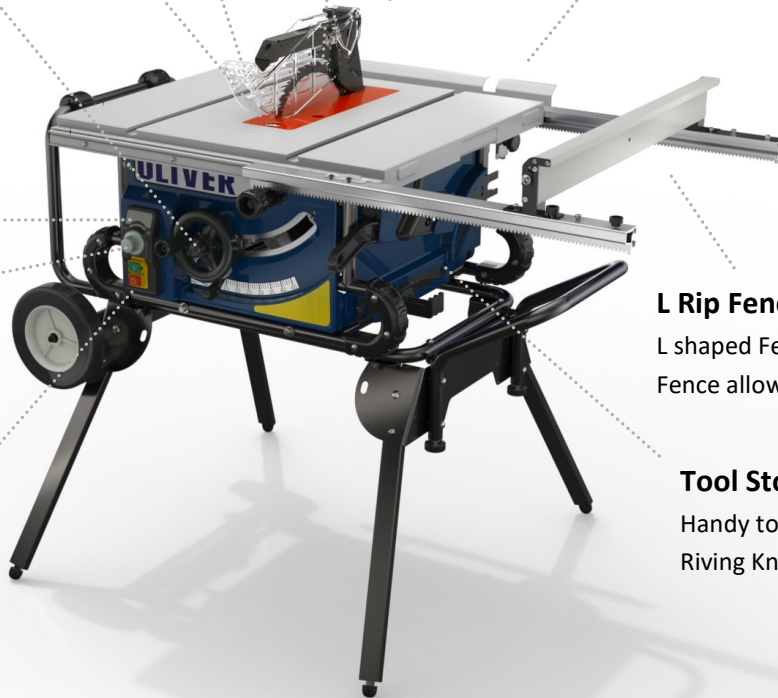

## SPECIFICATIONS

Brushless Motor	2HP 120VAC 50/60 HZ	Arbor	5/8"   15.875mm
Blade Diameter	10"   254mm	Arbor Variable Speed	1,700 ~ 5,000RPM
Rectangular Table Insert	Zero Clearance	Arbor Tilt Range	0° ~ 45° to left
Dado Diameter	8"   203.2mm	Table Material	ADC12
Dado Blade Set Max. Width	Up to 13/16"   21mm	Table Height	13.78"   350mm
Max. Depth of Cut	Blade at 90° 3 1/8"   79mm	Table Dimensions	25.2"x22.44"   640x570mm
Max. Depth of Cut	Blade at 45° 2 1/4"   57mm	Dust Port Diameter	2.5"   63.5mm
Max. Rip Right of Blade	24"   610mm	Net Weight	77.16lbs   35kgs



CHIU TING MACHINERY CO., LTD.  
No.78 Yuang Feng Rd Taiping District Taichung 411032 Taiwan  
FAX: 886-4-22701096 TEL: 886-4-22700258 <http://www.geetech.com.tw>